

**IN THE UNITED STATES DISTRICT COURT
FOR THE DISTRICT OF DELAWARE**

LEVITATION ARTS, INC.,

Plaintiff,

v.

PLOX, INC.,

Defendant.

C.A. No. 17-1476-MN

REPORT AND RECOMMENDATION

Pending before the Court is Plaintiff’s Motion for Default Judgment pursuant to Federal Rule of Civil Procedure 55(b). (D.I. 41.) I recommend that Plaintiff’s motion be GRANTED-IN-PART and DENIED-IN-PART.

I. BACKGROUND

Plaintiff Levitation Arts, Inc. filed this action alleging infringement of United States Patent No. 7,505,243 (the ’243 patent), entitled “Magnetic Levitation Apparatus.” (D.I. 1.) The ’243 patent describes an apparatus that uses magnets to make an object, such as a toy, levitate in air:

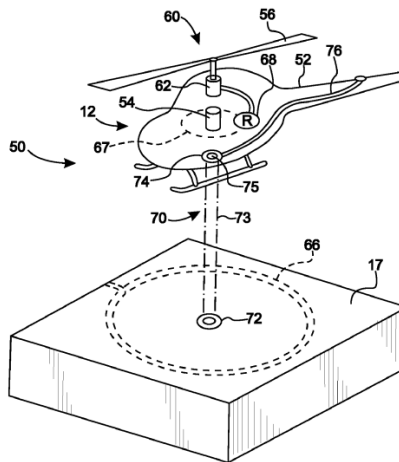

(’243 patent, 1:63-2:55, Fig. 6.) According to the specification, “[a] levitated object is interesting

to observe and can be useful in various applications.” (*Id.*, 1:20-22.)

Plaintiff is the assignee of the '243 patent. (D.I. 1 ¶ 8.) Plaintiff’s Complaint alleges that Defendant Plox, Inc. has infringed and continues to infringe the '243 patent by selling, offering for sale, and importing its Bluetooth-enabled Official Star Wars Levitating Death Star Speaker (the “Accused Product”):



(*Id.* ¶¶ 10, 12.)

Plaintiff alleges that the Accused Product “contain[s] each and every element of at least claims 16, 17, 19, 20, 21, 22, 23, 24, and 25 of the '243 patent both literally and under the doctrine

of equivalents.” (*Id.* ¶ 12.) The Complaint also provides more specific allegations that describe how the Accused Product meets each limitation of those claims.¹ (*Id.* ¶¶ 13-21.)

The Complaint alleges that Defendant’s infringement was willful. (*Id.* ¶ 23.) In support, the Complaint alleges that Plaintiff sent Defendant “a letter concerning intellectual property matters” on July 12, 2017. (*Id.*) The letter “enclosed a hardcopy of the ’243 patent, provided a link to online copies of the prosecution histories of [other] Patents, enclosed a patent claim chart describing the Accused Products’ infringement of certain claims of the ’243 patent on an element-by-element basis, and requested that Plox contact Levitation Arts’ counsel.” (*Id.*) According to the Complaint, Defendant’s “infringement . . . persisted” even after it received the letter. (*Id.*) The Complaint contains no other allegations regarding willfulness.

Plaintiff filed this action on October 18, 2017. Defendant answered the Complaint on January 1, 2018, denying infringement and asserting affirmative defenses of non-infringement and invalidity. (D.I. 8.) On March 22, 2018, the Court entered a Scheduling Order that set trial for

¹ For example, claim 16 requires, among other things, “a ring magnet disposed in a plane having a longitudinal axis and a latitudinal axis.” Paragraph 13 of the Complaint alleges the following regarding that element:

The Accused Product has a ring magnet within the base, which ring magnet is disposed in a plane having longitudinal and latitudinal axes.

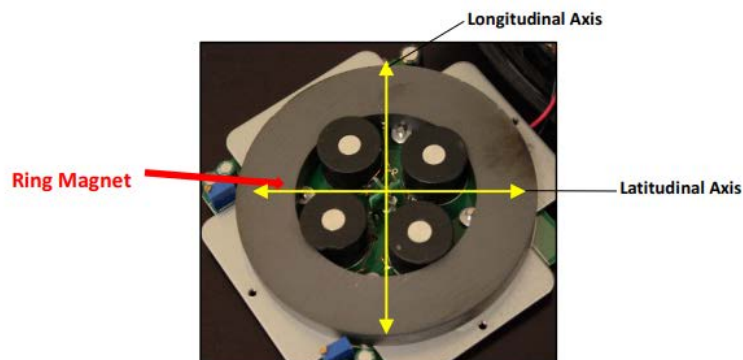

(D.I. 1 ¶ 13(b).)

December 2, 2019. (D.I. 12.) The docket indicates that the parties subsequently engaged in some discovery, including serving each other with infringement and invalidity contentions. (D.I. 15-19, 21, 23.²) The case was reassigned to the Honorable Maryellen Noreika on September 20, 2018.

On January 8, 2019, Defendant's then-counsel filed a motion for leave to withdraw. (D.I. 28.) The Court granted the motion on January 23, 2019 and directed Defendant to obtain new counsel no later than February 22, 2019. (D.I. 32.) Since that order, no attorney has entered an appearance for Defendant.

On July 9, 2019, Plaintiff filed a motion for default judgment. (D.I. 35.) On October 31, 2019, the Court granted the motion to the extent it was seeking entry of "default" against Defendant under Federal Rule of Civil Procedure 55(a). (D.I. 36, 37.) The Court denied Plaintiff's request for "default judgment" under Rule 55(b). (D.I. 36.) The Court directed Plaintiff to refile an application for default judgment after entry of default had been entered and served upon Defendant. (*Id.*)

On January 14, 2020, Plaintiff filed proof that it served Defendant's Delaware registered agent with the Court's entry of default. (D.I. 38, Ex. A.) Plaintiff also submitted evidence that its certified letter to Defendant's last known address in California was returned by the U.S. Postal Service as undeliverable. (*Id.*, Ex. B.)

On March 2, 2020, Plaintiff refiled its motion for default judgment pursuant to Rule 55(b). (D.I. 41.) The motion requests damages for patent infringement, enhanced damages, and attorney's fees. (*Id.*)

² Plaintiff contends that Defendant did not serve non-infringement or invalidity contentions. (D.I. 41 ¶ 15.) However, the docket reflects that Defendant served Plaintiff with something called "Defendant's Invalidity Contentions" on August 31, 2018. (D.I. 21 (Notice of Service).) Defendant's invalidity contentions are not in the record before me.

II. LEGAL STANDARD

Entry of default judgment is a two-step process. *Tristrata Tech., Inc. v. Med. Skin Therapy Research, Inc.*, 270 F.R.D. 161, 164 (D. Del. 2010). First, the party seeking a default judgment must request that the Clerk of Court enter default against the party that has failed to answer the pleading or otherwise defend itself in the action. Fed. R. Civ. P. 55(a); *see also J & J Sports Prod., Inc. v. Kim*, No. 14-1170, 2016 WL 1238223, at *1 (D. Del. Mar. 29, 2016). After default has been entered, a plaintiff may obtain a default judgment. Fed. R. Civ. P. 55(b); *see also J & J Sports Prod.*, 2016 WL 1238223, at *1. If the plaintiff is seeking relief in the form of a sum certain, it may obtain a default judgment from the Clerk of Court. Fed. R. Civ. P. 55(b)(1); *see also J & J Sports Prod.*, 2016 WL 1238223, at *1. Otherwise, “the party seeking default judgment must apply to the court for an entry of default judgment.” *Tristrata Tech.*, 270 F.R.D. at 164.

Courts have discretion over whether to enter a default judgment in a particular case. *See Hritz v. Woma Corp.*, 732 F.2d 1178, 1180 (3d Cir. 1984). The court considers three factors when determining if default judgment is appropriate: “(1) prejudice to the plaintiff if default is denied, (2) whether the defendant appears to have a litigable defense, and (3) whether defendant’s delay is due to culpable conduct.” *Chamberlain v. Giampapa*, 210 F.3d 154, 164 (3d Cir. 2000). For purposes of that determination, “the factual allegations of the complaint, except those relating to the amount of damages, will be taken as true.” *Genedics, LLC v. Meta Co.*, No. 17-1062, 2019 WL 3802650, at *3 (D. Del. Aug. 13, 2019) (quoting *Comdyne I, Inc. v. Corbin*, 908 F.2d 1142, 1149 (3d Cir. 1990)).

III. DISCUSSION

A. Patent Infringement

The relevant factors weigh in favor of entering default judgment on Plaintiff's patent infringement claim. First, the well-pleaded allegations of the Complaint establish that Defendant infringed Plaintiff's '243 patent. In particular, the Complaint contains factual allegations explaining how the Accused Product meets every element of the asserted claims of the '243 patent. (D.I. 1 ¶¶ 13-21.) *See also Genedics*, 2019 WL 3802650, at *3 (“[I]n a patent infringement case like this one, the Court here must presume that Defendant has infringed Plaintiff's patents as was alleged in Plaintiff's Complaint.”); *Tristrata Tech., Inc. v. Cardinal Health, Inc.*, No. 02-1290, 2004 WL 2223071, at *1 (D. Del. Sept. 30, 2004). The Complaint also alleges that Defendant sold, offered for sale, and imported the Accused Product in the United States. (*Id.* ¶ 10.) Plaintiff will suffer prejudice if its application for default judgment is denied because it would otherwise be unable to recover damages for the infringement.

Second, although Defendant's Answer set forth non-infringement and invalidity defenses, it has failed to pursue them through active litigation in this case. Third, while the reason for Defendant's failure to obtain substitute counsel is unclear, it is clear that Defendant was given ample time to obtain new counsel and failed to do so.

Based on the foregoing, I conclude that default judgment is appropriate.

B. Remedy

Finding that default judgment is appropriate, I next turn to the remedy. Plaintiff requests damages based on a reasonable royalty, enhanced damages under 35 U.S.C. § 284, and attorney's fees under 35 U.S.C. § 285.

Plaintiff requests reasonable royalty damages in the amount of \$289,575.00.³ I do not have to take as true Plaintiff's factual allegations regarding the amount of damages. *Christ v. Cormick*, Nos. 06-275, 07-060, 2008 WL 4889127, at *1 (D. Del. Nov. 10, 2008). Rather, pursuant to Rule 55(b), I must make a finding as to the amount of damages based on the evidence in the record. Fed. R. Civ. P. 55(b); *see also Christ*, 2008 WL 4889127, at *1.

I find that Plaintiff's request for \$289,575.00 is appropriate and supported by the record. Plaintiff calculated its proposed damages using a simple formula: damages = (price of Accused Product) × (# of Accused Products sold) × (royalty rate). As to the price of the Accused Product, Plaintiff submitted evidence supporting its estimation that Defendant sold the Accused Product at an average price of \$179.99. (D.I. 41 ¶¶ 30-32; D.I. 42 ¶¶ 5-9, Exs. B, C.) As to the number of Accused Products sold, Plaintiff submitted evidence in the form of a sales report produced by Defendant in this litigation. (D.I. 41 ¶ 30; D.I. 42 ¶¶ 3-4, Ex. A.) As to the reasonable royalty rate, Plaintiff submitted evidence of an "established royalty" for a license under the '243 patent for devices that, like the Accused Product, consist of spherical, levitating Bluetooth speakers. (D.I. 41 ¶¶ 28-29; D.I. 43 ¶¶ 3-7, Ex. A.) *See Wordtech Sys., Inc. v. Integrated Network Sols., Inc.*, 609 F.3d 1308, 1319 (Fed. Cir. 2010) ("A reasonable royalty can be calculated from an established royalty, the infringer's profit projections for infringing sales, or a hypothetical negotiation between the patentee and infringer . . ."). Plugging those variables in to the formula results in a reasonable royalty of \$289,575.00.

Plaintiff also requests that the Court treble its damages under 35 U.S.C. § 284. Unlike the record in support of reasonable royalty damages, the evidence supporting Plaintiff's request for

³ Plaintiff alleges, and I take as true, that it "has complied with 35 U.S.C. § 287." (D.I. 1 ¶ 22.) *See* 35 U.S.C. § 287 (limiting damages where a patentee fails to mark the patented article).

enhanced damages is minimal. After careful consideration, I recommend that the Court exercise its discretion to not award enhanced damages.

Section 284 provides that “the court may increase the damages up to three times the amount found or assessed.” 35 U.S.C. § 284. The Supreme Court has directed that enhanced damages “are not to be meted out in a typical infringement case, but are instead designed as a sanction for egregious infringement behavior” described as “willful, wanton, malicious, bad-faith, deliberate, consciously wrongful, flagrant, or—indeed—characteristic of a pirate.” *Halo Elecs., Inc. v. Pulse Elecs., Inc.*, 136 S. Ct. 1923, 1932 (2016); *see also SRI Int’l, Inc. v. Cisco Sys., Inc.*, 930 F.3d 1295, 1308 (Fed. Cir. 2019), *cert. denied*, 140 S. Ct. 1108 (2020). That said, the court has discretion to decline to award enhance damages even in cases where willful infringement is found. *Halo Elecs.*, 136 S. Ct. at 1933; *Idenix Pharm. LLC v. Gilead Scis., Inc.*, 271 F. Supp. 3d 694, 698 (D. Del. 2017). Thus, even where infringement is willful, the court must still “take into account the particular circumstances” and make a determination as to whether enhanced damages are warranted. *Halo Elecs.*, 136 S. Ct. at 1933; *see also Idenix Pharm.*, 271 F. Supp. 3d at 697.

Here, Plaintiff alleges, and I take as true, that Defendant’s infringement was willful. (D.I. 1 ¶ 23.) Nevertheless, after carefully reviewing the entirety of the record before me, I cannot conclude that Defendant’s actions went beyond what this Court encounters in a typical infringement case. I have carefully reviewed Plaintiff’s Complaint, which attaches the ’243 patent and describes how Defendant’s Accused Product meets each limitation of the asserted claims. The allegations relevant to willfulness are set forth in one paragraph of the Complaint, which alleges that Plaintiff sent Defendant a claim chart containing Plaintiff’s infringement contentions and that Defendant nevertheless continued to infringe. (*Id.*) Plaintiff’s briefing also points out that Defendant continued to infringe for five months after Plaintiff filed its Complaint. (D.I. 41 ¶ 38.)

In my view, those facts, without more, do not warrant enhanced damages. As the Federal Circuit has explained, “it is the circumstances that transform simple ‘intentional or knowing’ infringement into egregious, sanctionable behavior, and that makes all the difference.” *SRI Int’l*, 930 F.3d at 1308 (quoting *Halo Elecs.*, 136 S. Ct. at 1936 (Breyer, J., concurring)). The circumstances in the record before me demonstrate “a typical infringement case,” not “egregious infringement behavior.” See *Halo Elecs.*, 136 S. Ct. at 1932; see also *LF Centennial Ltd. v. Inovex Furnishings Corp.*, No. 17-5824, 2019 WL 6655258, at *7 (C.D. Cal. Oct. 2, 2019) (declining to award enhanced damages on a motion for default judgment, notwithstanding the plaintiff’s allegation that it sent the defendant notice of infringement prior to filing the complaint and that the defendant continued to infringe during the pendency of the case); *Arnold v. Scales*, No. 15-45, 2016 WL 6155173, at *1 (M.D. Ga. Feb. 5, 2016) (finding that the defendant acted willfully but declining to award enhanced damages in a default judgment). But see *Tech. LED Intellectual Prop., LLC v. Aeon Labs LLC*, No. 18-1847, 2020 WL 1528446, at *2–3 (N.D. Cal. Mar. 31, 2020) (awarding double damages on a default judgment only for post-complaint infringement).

Plaintiff argues that “Defendant’s refusal to appear, participate, or present a litigable defense to Plaintiff’s claims” weighs in favor of enhanced damages. (D.I. 41 ¶ 39.) Under the particular circumstances here, I disagree. Plaintiff has not argued that Defendant’s invalidity positions were weak, nor did Plaintiff submit Defendant’s contentions to the Court for review. The docket indicates that Defendant initially engaged in some discovery but that it failed to obtain substitute counsel after Defendant’s original attorney withdrew. Considering all of that, in light of what turned out to be the amount in controversy—less than \$300,000—and in view of the average cost to defend a patent infringement case—more than \$300,000—I cannot say that Defendant’s abandonment of its defense evidences egregious conduct as opposed to an economic

decision. Accordingly, I recommend that the Court exercise its discretion to not award enhanced damages.

Plaintiff also requests that the Court award attorney's fees under 35 U.S.C. § 285. Section 285 provides that a "court in exceptional cases may award reasonable attorney fees to the prevailing party." 35 U.S.C. § 285. "[A]n 'exceptional' case is simply one that stands out from others with respect to the substantive strength of a party's litigating position (considering both the governing law and the facts of the case) or the unreasonable manner in which the case was litigated." *Octane Fitness, LLC v. ICON Health & Fitness, Inc.*, 572 U.S. 545, 554 (2014); see also *SRI International*, 930 F.3d at 1310. "The party seeking fees must prove that the case is exceptional by a preponderance of the evidence, and the district court makes the exceptional case determination on a case-by-case basis considering the totality of the circumstances." *SRI International*, 930 F.3d at 1310.

I recommend that the Court exercise its discretion to not award attorney's fees. Again, Plaintiff has not argued that Defendant's invalidity positions were weak, and there is nothing in the record to suggest that Defendant had an unjustified litigating position. Moreover, other than its failure to defend, it does not appear that Defendant engaged in unreasonable litigation tactics. In my view, the failure to defend is not enough to make this case exceptional. See *LF Centennial*, 2019 WL 6655258, at *8 (declining to award attorney's fees under 35 U.S.C. § 285 on a default judgment, notwithstanding the defendant's failure to secure new counsel after its original counsel withdrew); *Tzu Techs., LLC v. Winzz, LLC*, No. 15-5493, 2016 WL 6822754, at *9 (C.D. Cal. June 14, 2016) ("The bare default finding of willful infringement is insufficient evidence of exceptional circumstances to warrant an attorneys'-fees award. . . . Neither default judgments nor willful infringement are uncommon in patent-infringement cases."). I also note that Plaintiff has obtained

the full amount of its requested reasonable royalty despite having spent far less on attorney's fees than it would have if the case had progressed. Accordingly, I recommend that the Court decline to award attorney's fees.⁴

VI. CONCLUSION

For the foregoing reasons, I recommend that Plaintiff's motion for default judgment pursuant to Federal Rule of Civil Procedure 55(b) be GRANTED-IN-PART and DENIED-IN-PART. Accordingly I recommend that the Court enter an Order of Default Judgment in favor of Plaintiff and against Defendant

1. finding that Defendant is liable for infringing Plaintiff's '243 patent;
2. awarding Plaintiff compensatory damages in the amount of \$289,575.00 based on a reasonable royalty under 35 U.S.C. § 284;
3. declining to award enhanced damages under 35 U.S.C. § 284; and
4. declining to award attorney's fees under 25 U.S.C. § 285.

This Report and Recommendation is filed pursuant to 28 U.S.C. § 636(b)(1)(B),(C), Federal Rule of Civil Procedure 72(b)(1), and District of Delaware Local Rule 72.1. Any objections to the Report and Recommendation shall be filed within fourteen days and limited to ten pages. Any response shall be filed within fourteen days thereafter and limited to ten pages. The failure of a party to object to legal conclusions may result in the loss of the right to *de novo* review in the district court.

The parties are directed to the Court's "Standing Order for Objections Filed Under Fed. R. Civ. P. 72," dated October 9, 2013, a copy of which can be found on the Court's website.

⁴ Plaintiff's motion and proposed order do not address pre-judgment interest, post-judgment interest, or costs. (See D.I. 41 at 12, Proposed Order.) Accordingly, this Report and Recommendation does not address them.

Dated: May 26, 2020

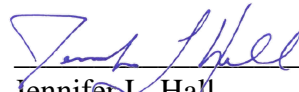

Jennifer L. Hall

UNITED STATES MAGISTRATE JUDGE